



# Installation Manual

**MPack 261A**



○ E-mail: [support@renon-usa.com](mailto:support@renon-usa.com)

**2025 1<sup>ST</sup> EDITION**

© Renon Power USA LLC.  
All rights reserved. Specifications are subject to change without notice.

**Buyer:**  
\_\_\_\_\_

**Supplier:**  
\_\_\_\_\_  
\_\_\_\_\_

# Renon Power

## We Care About Sustainability

With our own R&D team and automatic production factory, we are dedicated to delivering innovative, reliable, and affordable energy storage solutions to global customers.

At Renon, we believe that sustainable energy is the future. We are passionate about reducing carbon emissions and preserving our planet for future generations. That's why we invest heavily in research and development, leveraging the latest technologies to design and manufacture energy storage systems that are efficient, scalable, and adaptable.

Our products are designed to meet the needs of a wide range of applications, from residential and commercial buildings to industrial facilities and utility-scale projects. Whether you're looking to reduce your energy bills, increase your energy independence, or support your sustainability goals, Renon has the right solution for you.

Our commitment to quality and customer satisfaction is unwavering. We work closely with our clients to understand their unique needs and provide customized solutions that meet or exceed their expectations. We also provide comprehensive technical support, maintenance, and warranty services to ensure that our customers get the most out of their investment.

[Join us on our mission to make renewable energy within reach.](#)

---

PROVIDE **INNOVATIVE,**  
**RELIABLE, AND**  
**AFFORDABLE ENERGY**  
**STORAGE SOLUTIONS**  
**TO CUSTOMERS**  
**WORLDWIDE.**

---



## CONTENTS

<b>1. PREFACE .....</b>	<b>- 1 -</b>
1.1. APPLICABLE PRODUCTS .....	- 1 -
1.2. APPLICABLE AUDIENCE .....	- 1 -
1.3. SYMBOL DEFINITIONS .....	- 1 -
<b>2. SAFETY PRECAUTIONS .....</b>	<b>- 2 -</b>
2.1. GENERAL SECURITY .....	- 2 -
2.2. SYSTEM SAFETY .....	- 2 -
2.3. LABEL INSTRUCTIONS .....	- 3 -
2.4. BATTERY SAFETY .....	- 4 -
2.5. PERSONNEL REQUIREMENTS .....	- 4 -
<b>3. PRODUCT PROFILE .....</b>	<b>- 5 -</b>
3.1. SIZE .....	- 5 -
3.2. SURFACE .....	- 5 -
3.3. INTRODUCTION TO KEY COMPONENTS .....	- 6 -
<b>4. STRUCTURE FIXATION AND INSTALLATION .....</b>	<b>- 7 -</b>
4.1. SPACE REQUIREMENTS .....	- 7 -
4.2. FOUNDATION REQUIREMENTS .....	- 8 -
4.3. HANDLING REQUIREMENTS .....	- 9 -
4.3.1. <i>Forklift Transport</i> .....	- 9 -
4.3.2. <i>Crane Transport</i> .....	- 9 -
4.4. INSTALL ENCLOSURE PANELS AND SECURE THE CABINET .....	- 10 -
4.5. DOOR OPENING ANGLE .....	- 10 -
<b>5. ELECTRICAL CONNECTION .....</b>	<b>- 11 -</b>
5.1. ELECTRICAL WIRING DIAGRAM .....	- 11 -
5.1.1. <i>Standard Cabinet</i> .....	- 11 -
5.1.2. <i>MPPT Unit&amp; MPPT PDU (Optional)</i> .....	- 12 -

5.1.3. STS Box (Optional) ..... - 12 -

5.2. PRE-WIRING PREPARATION ..... - 14 -

    5.2.1. Tool Preparation ..... - 14 -

    5.2.2. Cable Preparation ..... - 15 -

5.3. PROTECTIVE EARTH CABLE CONNECTION ..... - 15 -

    5.3.1. Protective Grounding (PE) ..... - 15 -

    5.3.2. Functional Grounding (FG) ..... - 16 -

5.4. AUXILIARY POWER SUPPLY CABLE CONNECTION ..... - 16 -

5.5. AC CABLE CONNECTION ..... - 17 -

5.6. DC CABLE CONNECTION ..... - 17 -

5.7. COMMUNICATION AND CONTROL CABLE CONNECTION (RESERVED) ..... - 18 -

5.8. BATTERY MAINTENANCE SWITCH DISCONNECT DEVICE (MSD) ..... - 19 -

**6. TEST OPERATION OF EQUIPMENT ..... - 20 -**

    6.1. CHECK BEFORE CHARGING ..... - 20 -

    6.2. POWER ON ..... - 20 -

    6.3. POWER DOWN ..... - 22 -

    6.4. EQUIPMENT DOOR-CLOSE ..... - 22 -

    6.5. EMERGENCY STOP ..... - 23 -

**7. REVISION TABLE ..... - 23 -**

# 1. Preface

This manual primarily covers the product information, installation instruction and power-on/off procedures. Before installing and using this product, it is imperative to thoroughly read this manual. Doing so will ensure your understanding of the safety information and acquaint you with the features and characteristics of the product.

## 1.1. Applicable Products

This manual applies to the **MPack 261A** .The product models include:

No.	Configuration	Product Model
1	MPack 261A Standard Cabinet	R-MP261135A1-US
2	Standard Cabinet + STS Box	R-MP261135A1-S-US
3	Standard Cabinet + MPPT Unit(120kW total) + MPPT PDU	R-MP261135A1-P-US
4	Standard Cabinet + MPPT Unit(120kW total) + MPPT PDU + STS Box	R-MP261135A1-SP-US

## 1.2. Applicable Audience

This manual is intended for professional personnel who are familiar with local regulations and standards, have undergone specialized training, and possess a thorough knowledge of this product.

## 1.3. Symbol Definitions

For better use of this manual, the following symbols are used to highlight important information. Please read the symbols and instructions carefully.

<b>Danger</b>
Indicates a high potential for danger.Failure to avoid this hazard could result in death or serious injury.
<b>Warning</b>
Indicates a moderate potential for danger.Failure to avoid this hazard could result in death or serious injury.
<b>Caution</b>
Indicates a low potential for danger.Failure to avoid this hazard could result in moderate or minor injury.
<b>Note</b>
Indicates an emphasis or supplement to the content.It may also provide tips or tricks for optimizing the use of the product, helping you resolve issues or save time.

## 2. Safety Precautions

When operating the equipment, it is imperative to comply with all safety precautions contained herein.

Note
The equipment has been designed in strict accordance with the safety regulations and qualified for the test, but as electrical equipment, the relevant safety instructions shall be observed before any operation of the equipment, and any improper operation may lead to serious injury or property loss.

### 2.1. General Security

Note
<ul style="list-style-type: none"> <li>● This manual may be updated periodically due to product upgrades or other reasons. This manual does not take precedence over, and shall not be used to override, the safety warnings and precautions printed on the product labels. All information herein is provided for guidance only and does not constitute a warranty of any kind.</li> <li>● Carefully read this manual before installing the equipment to understand the product and relevant precautions.</li> <li>● All operations on the equipment must be performed by qualified electrical technicians who are familiar with the relevant standards and safety regulations applicable to the project location.</li> <li>● When working on the equipment, always use insulated tools and wear appropriate personal protective equipment (PPE). When handling electronic components or internal assemblies, additional anti-static measures (such as gloves, wrist straps, and clothing) must be taken to prevent electrostatic discharge (ESD) damage.</li> <li>● The manufacturer is not responsible for equipment damage or personal injury caused by failing to install, use, or configure the equipment according to this manual or the corresponding user manual. For more information on product warranties, please visit the official website.</li> </ul>

### 2.2. System Safety

Danger
<ul style="list-style-type: none"> <li>● Always observe all safety precautions and warnings contained in this manual, any accompanying documentation, and on the product labels.</li> <li>● Strictly comply with all local laws, regulations, and industry standards when operating the equipment.</li> <li>● Transportation &amp; Handling: Ensure transport personnel are professionally trained. During loading, unloading, and movement, use appropriate equipment and follow procedures to maintain balance and prevent drops. Avoid rough handling, as impacts can damage the battery racks, potentially causing short circuits, electrolyte leakage, fire, or explosion. Comply with all local regulations and industry standards for handling heavy equipment.</li> <li>● This is heavy equipment. Always use suitable lifting tools and take all necessary protective measures during installation and maintenance to prevent personal injury or equipment damage.</li> <li>● The equipment contains lethal high voltage. Never touch any internal or external conductive parts unless power is confirmed off and locked out.</li> <li>● Only trained and authorized professionals may open battery rack doors or access internal components.</li> </ul>

- Do not operate the equipment if it is damaged, faulty, or indicates an alarm (including ground fault alarms). An active alarm does not guarantee the absence of hazardous voltage. Operating faulty equipment increases the risk of electric shock and fire.
- Before any work, ensure the system is properly grounded and that all required safety measures (lockout/tagout) are in place.
- The system must be properly grounded upon installation. Before performing any operation, verify that all safety measures are in place to prevent electric shock.







**Warning**

- Do not strike, pull, drag, or step on the equipment. Do not pierce the equipment casing with sharp objects.
- Do not place any unrelated objects inside the battery racks.
- The equipment is equipped with an automatic fire suppression system. Activate the manual suppression switch ONLY in case of fire emergency.
- All cables must comply with local electrical codes and regulations.
- The voltage and frequency at the grid connection point MUST meet the specifications specified for the battery racks.
- Circuit breakers or fuses MUST be installed on the AC side of the equipment as overcurrent protection devices.
- Do not install the equipment in high-temperature environments or near heat sources.

**Danger**

After installation, ensure that the labels and warning signs on the battery racks are clearly visible. Do not obstruct, deface, or damage them .

**2.3. Label Instructions**

	<p>High voltage danger. There is high pressure during the equipment. When operating the equipment, make sure the equipment is powered off.</p>		<p>Potential hazard after equipment operation. When operating, please protect yourself.</p>
	<p>There is high temperature on the surface of the equipment, no touch when the equipment is running, otherwise it may cause scald.</p>		<p>Protect the ground wire connection point.</p>
	<p>Battery recycling: the equipment should not be treated as household waste. Please treat the equipment according to local laws and regulations, or send it back to the equipment manufacturer.</p>		<p>System recycling: the equipment should not be treated as household waste, please treat the equipment according to the local laws and regulations.</p>

## 2.4. Battery Safety

### Warning

If the battery leaks electrolyte, avoid contact with the leaked liquid or gas. Electrolyte is corrosive and can cause skin irritation and chemical burns. If contact occurs, follow these steps:

- Eye Contact: Rinse eyes with water for at least 15 minutes and seek medical assistance immediately.
- Skin Contact: Wash the affected area thoroughly with soap and water and seek medical assistance immediately.
- Inhalation: Move away from the contaminated area and seek medical assistance immediately.
- Ingestion: Induce vomiting and seek immediate medical attention.

### Warning

- A burning battery may release toxic and harmful gases.
- In the event of a fire, immediately call the fire department and notify firefighters, providing them with relevant product information.
- If safe to do so, disconnect the power supply to the equipment by turning off the upstream and downstream switches.

## 2.5. Personnel Requirements

### Note

- Personnel responsible for the installation and maintenance of the equipment must undergo rigorous training to understand all safety precautions and master the correct operating procedure.
- Installation, operation, maintenance, and replacement of the equipment or its Instructions should only be performed by qualified professionals or trained personnel.

### 3. Product Profile

#### 3.1. Size

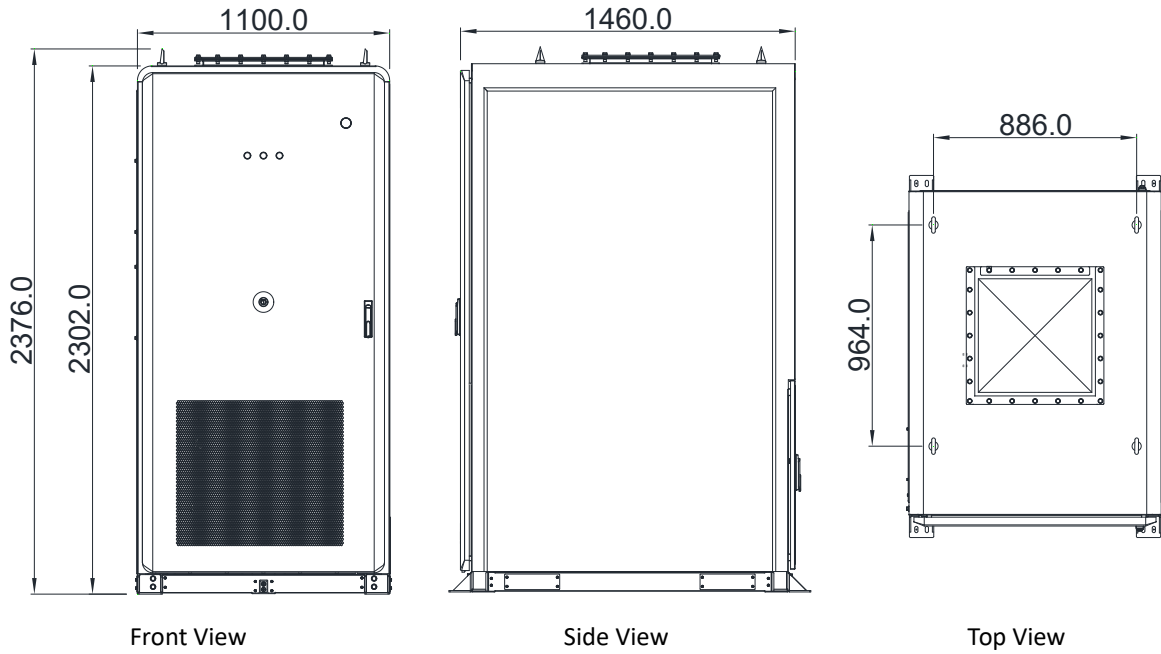

#### 3.2. Surface

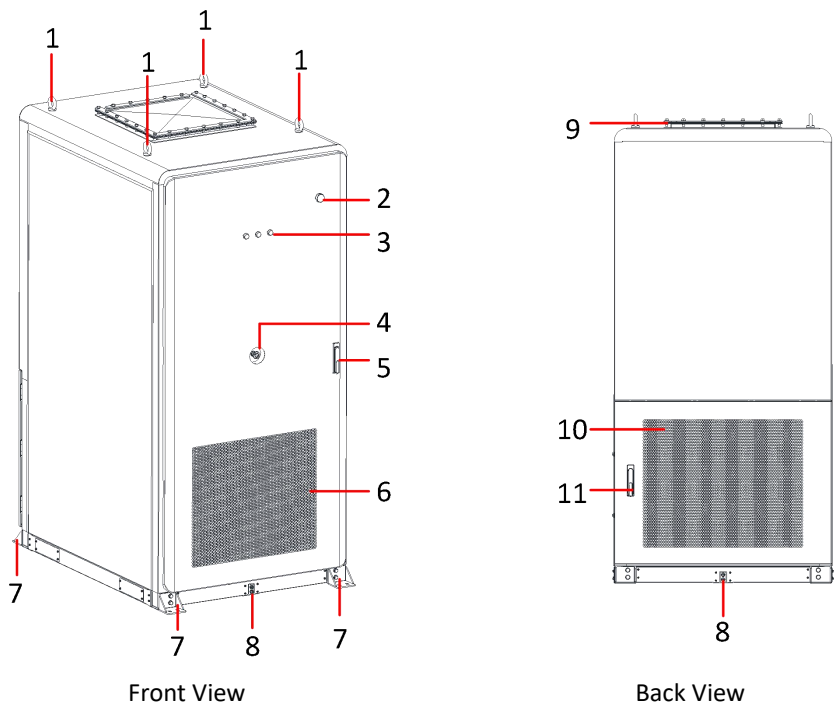

No.	Project	Instructions
1	Lifting Ring	Can use lifting rings for hoisting the cabinet.
2	WIFI&4G	Can connect to WiFi&4G to improve wireless communication signal strength.
3	LED Indicators	Stop Light、Fault Light、Run Light
4	Emergency Stop	When an emergency occurs, this button can be used to stop the system from operating.
5	Front Door Lock	Please use a key to unlock the door. When no internal operation is needed, please close and securely lock the door.
6	Air Intake	Introduce external air into the internal part of the ESS.
7	Mounting Hole	Fix mounting.
8	Grounding Terminal	For equipment grounding.
9	Explosion Vent Panel	ESS explosion vent rapidly relieves pressure during thermal runaway.
10	Air Outlet	Emit the air that has been heated or circulated from within the cabinet.
11	Rear Door Lock	Please use a key to unlock the door. When no internal operation is needed, please close and securely lock the door.

### 3.3. Introduction to Key Components

The internal layout and external mounting layout of a single MPack 261A are shown below.

\*MPPT Unit, MPPT PDU, and STS Box are optional.

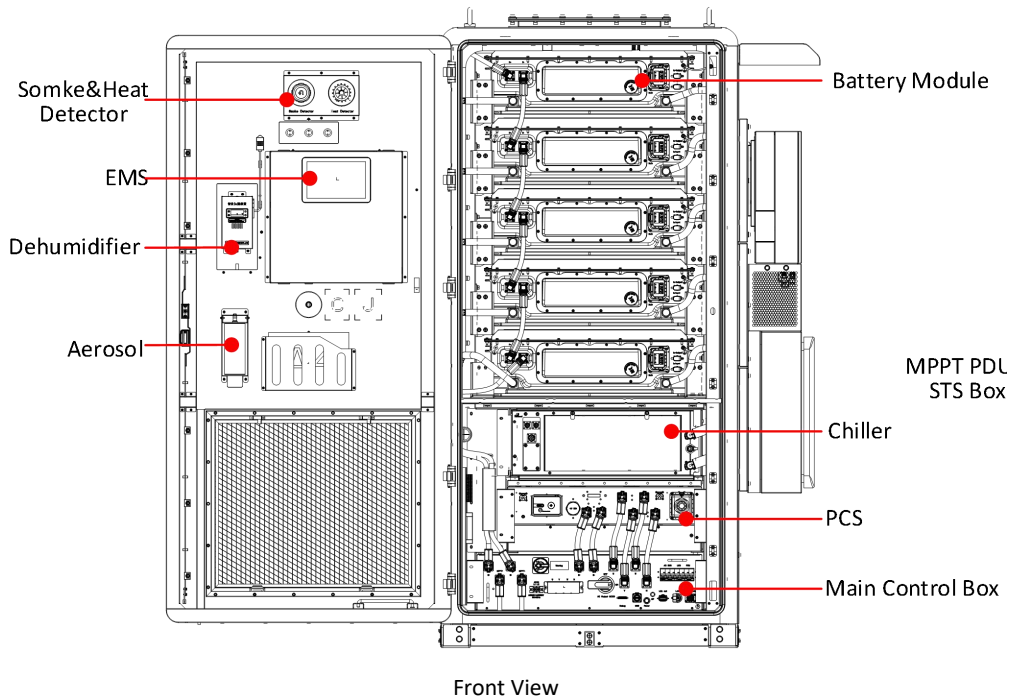

The following figure illustrates the external layout of the **R-MP261135A1-SP-US** (Standard Cabinet + MPPT Unit + MPPT PDU + STS Box) in both single-unit and two-unit parallel configurations.

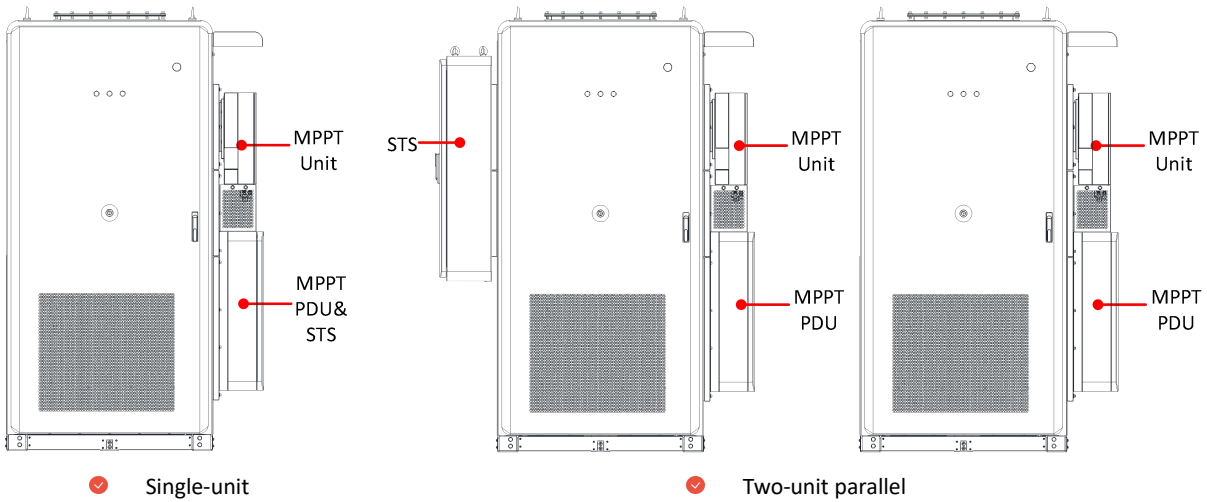

## 4. Structure Fixation and Installation

### 4.1. Space Requirements

To ensure proper ventilation and maintenance access for the MPack 261A cabinet, sufficient clearance must be provided around the installation site. The diagram below illustrates the airflow (intake/exhaust) and minimum space requirements.

- Minimum Space Requirement for Cabinet Installation and Maintenance: A minimum 98.4in (2500mm) front clearance is required to provide enough space for installation and maintenance.
- Airflow Intake & Exhaust Illustration: To ensure proper ventilation during operation, keep at least 47.2in(1200mm) of clearance in front of and behind the cabinet.

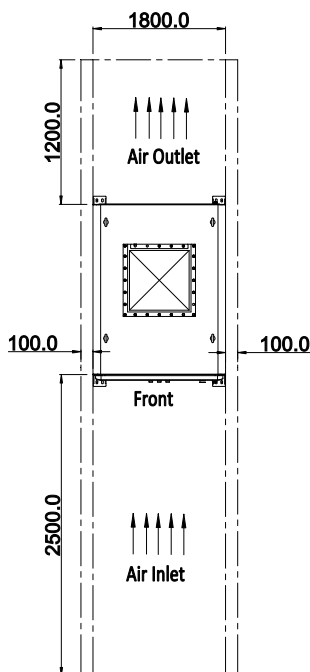

✓ The MPack 261A (Standard Cabinet)

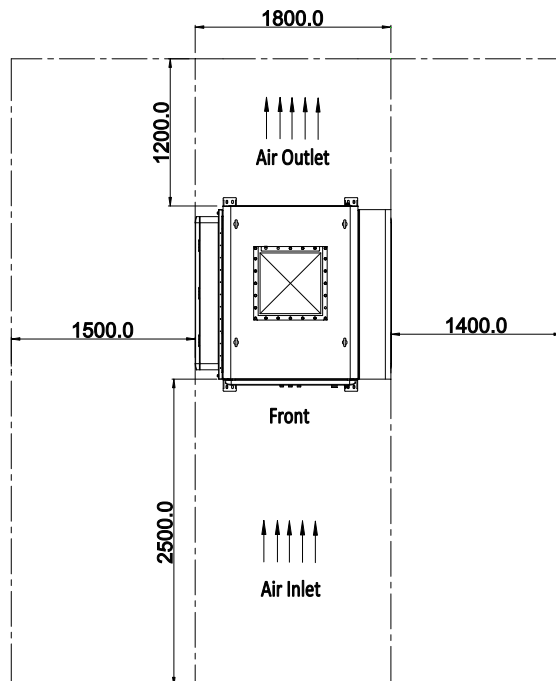

✓ The MPack 261A (With External Equipment)

## 4.2. Foundation Requirements

The base of the battery cabinet can be constructed using either concrete or channel steel. The attached diagrams and table specify the requirements for concrete base, including but not limited to: soil compaction standard, materials, surface tolerance, and load-bearing capacity. If steel channel brackets are selected as an alternative solution, they must meet equivalent key performance criteria.

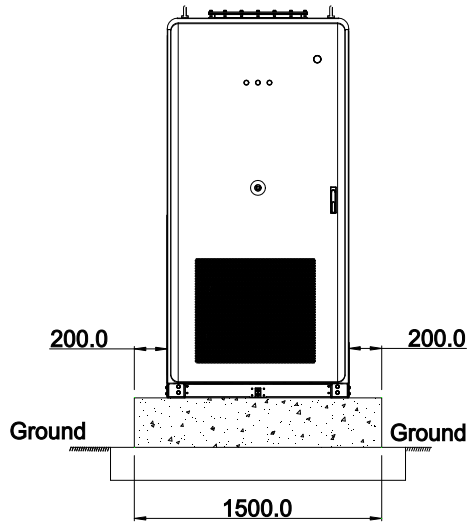

✓ Standard Cabinet (Front View)

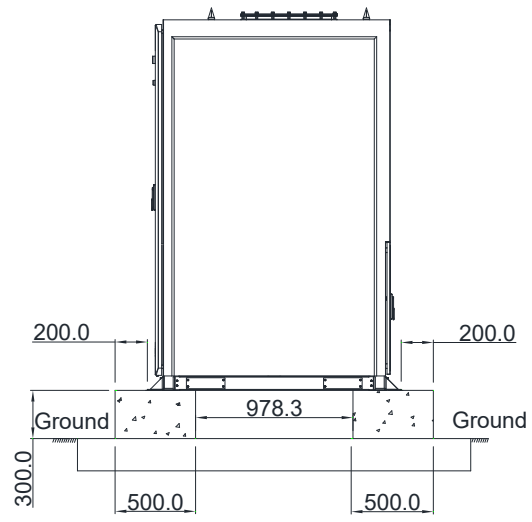

✓ Standard Cabinet (Side View)

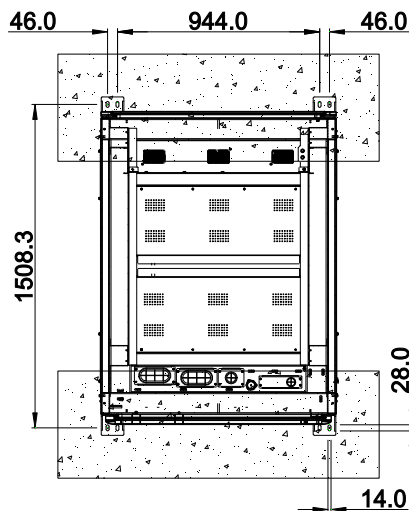

✓ Standard Cabinet (Top View)

Notice		
1	Excavation & Soil Compaction	<ul style="list-style-type: none"> <li>➤ During foundation excavation, the subgrade soil must be properly compacted.</li> <li>➤ Loose, wet, or organic soils require ground improvement (e.g., soil replacement or stabilization).</li> <li>➤ The foundation shall be sited at the highest local elevation to prevent water accumulation.</li> </ul>
2	Materials	<ul style="list-style-type: none"> <li>➤ Structure: C30 structural concrete, minimum bearing capacity of 4000kg/m<sup>2</sup>.</li> </ul>
3	Surface Flatness	<ul style="list-style-type: none"> <li>➤ Level the foundation surface and ensure its surface is within 0.2in(5mm) of the floor level. If deviation is excessive, relevel by readjusting the four cabinet base support brackets.</li> </ul>

4	Load Distribution	➤ The concrete pedestal must be level and have a smooth surface to ensure uniform load distribution for the product's total weight of 6393lb (2900kg) ±5%.
5	General Notes	➤ This drawing is for schematic guidance only. The final design must comply with local codes and site conditions. ➤ Fireproofing: After installation, seal all cable outlets with fireproof putty.

### 4.3. Handling Requirements

Note	
➤	During all ESS lifting operations, strict adherence to safe lifting practices is mandatory.
➤	Establish and enforce a 197in(5m) exclusion zone around the lift area. Under no circumstances may personnel stand under the lifting boom or any suspended load.
➤	Lifting must cease immediately in adverse weather conditions, including rain, fog, or strong winds.

#### 4.3.1. Forklift Transport

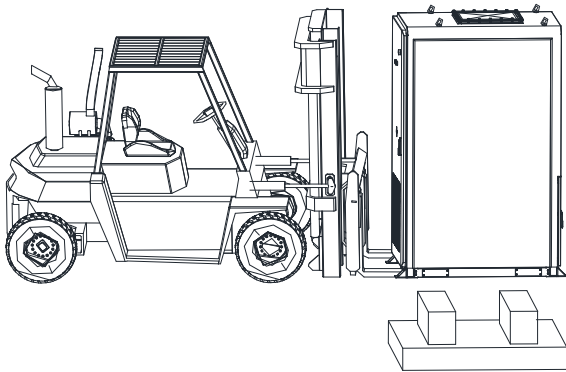

- Forklift Selection: Choose a forklift based on the installation area's space constraints. It is recommended to use an internal combustion engine-driven forklift with a rated load capacity exceeding 8818.5lb (4000kg).
- Fork Arm Requirements: The fork arms must be longer than 63in(1600mm) and the width is 25.6in-29.5in (650mm-750mm).
- Forklift Angle: Lift from the front/back of the battery cabinet, not the side of the cabinet (as shown in the diagram on the left).
- Forklift movement is prohibited once cables are connected.

#### 4.3.2. Crane Transport

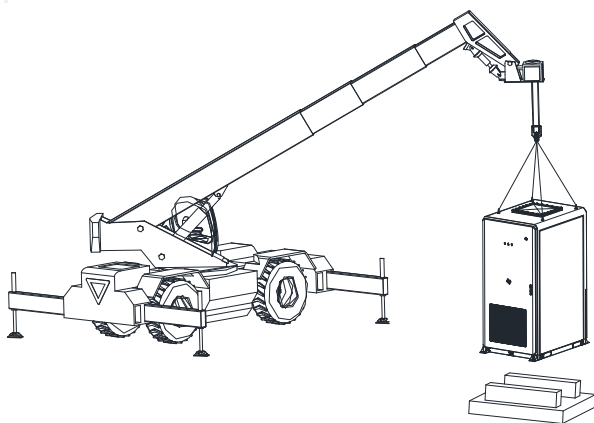

- Select a crane with a load capacity of ≥11023lb (5000kg).
- Use four lifting slings, with each sling having a recommended load capacity of ≥4409.3lb (2000kg).
- Use the four standard lifting rings located on the top of the cabinet as lifting points.
- Attach each lifting strap between a lifting lug and the crane hook.
- Hoisting: Slowly lift the cabinet 7.9in~11.8in (200~300mm) off the ground and ensure there is no obvious inclination of the cabinet. Lift the cabinet at a uniform speed to avoid shaking and tilting. Move slowly to the target position and ensure stable placement.

### 4.4. Install Enclosure Panels and Secure the Cabinet

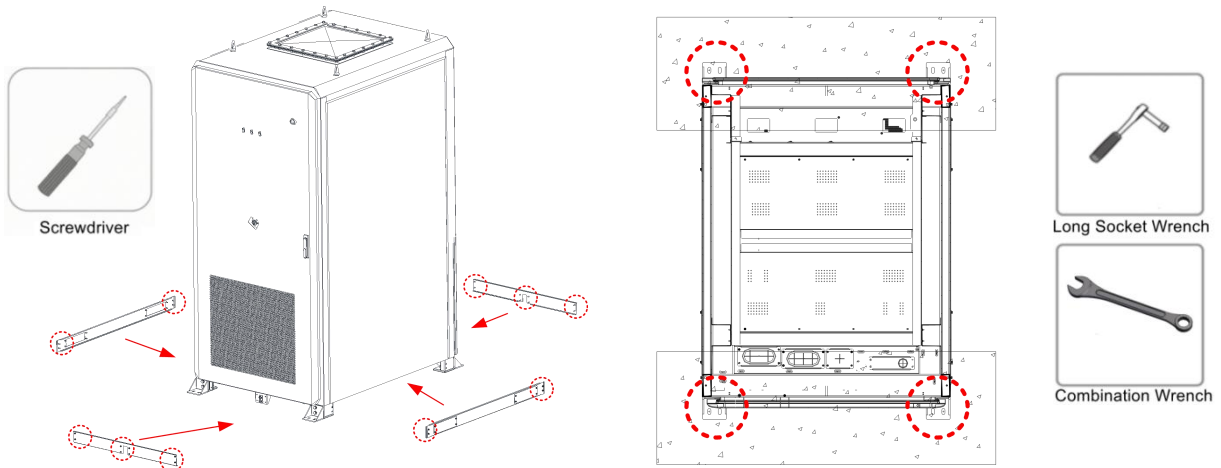

① Use a screwdriver to secure the enclosure panels with M5 bolts (Torque: 3N·m).

② Use a long socket wrench or combination wrench to secure the cabinet with M12×150 expansion bolts (Torque: 50N·m).

### 4.5. Door Opening Angle

The following image illustrates the maximum door opening angle (<math><110^\circ</math>) for both the standard cabinet and the cabinet with externally mounted equipment. After opening the door, please use the windproof hook (installed at the bottom of the door) to secure it and prevent it from slamming shut due to wind.

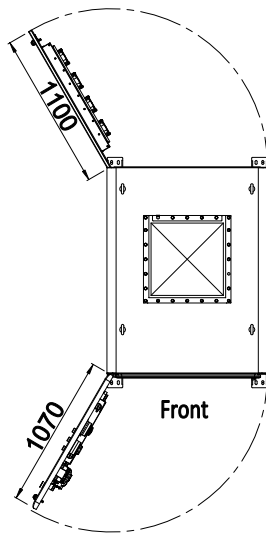

✓ The MPack 261A (Standard Cabinet)

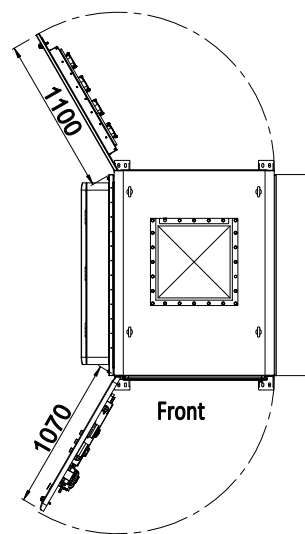

✓ The MPack 261A (With External Equipment)

## 5. Electrical connection

### Danger

- Do not touch live parts.
- Before wiring, ensure the polarity of all input cables is correct for each circuit.
- Never pull cables or wires forcefully to prevent insulation damage.
- Ensure all cables/wires have sufficient bending space/flexibility to avoid strain.
- Use strain relief measures (e.g., ties) to minimize mechanical stress on cables.
- After each wiring step, inspect connections to ensure they are secure and correctly installed.

### 5.1. Electrical Wiring Diagram

#### 5.1.1. Standard Cabinet

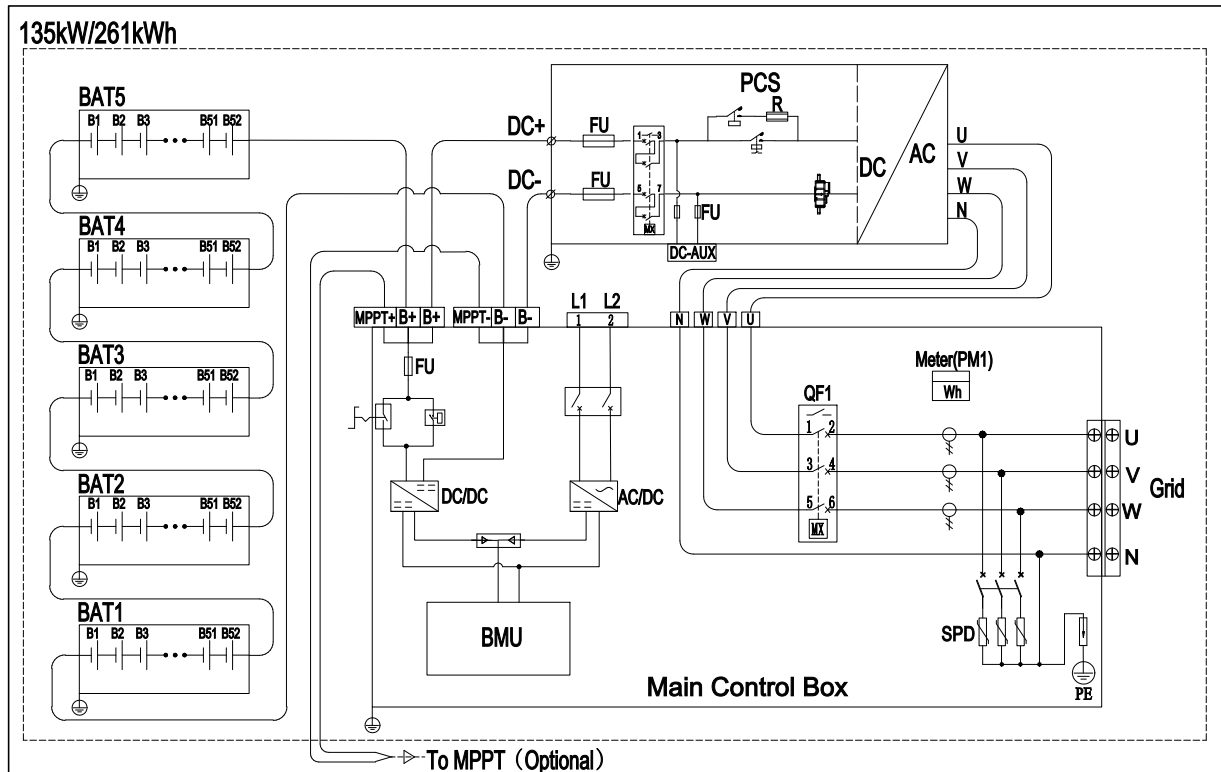

### 5.1.2. MPPT Unit & MPPT PDU (Optional)

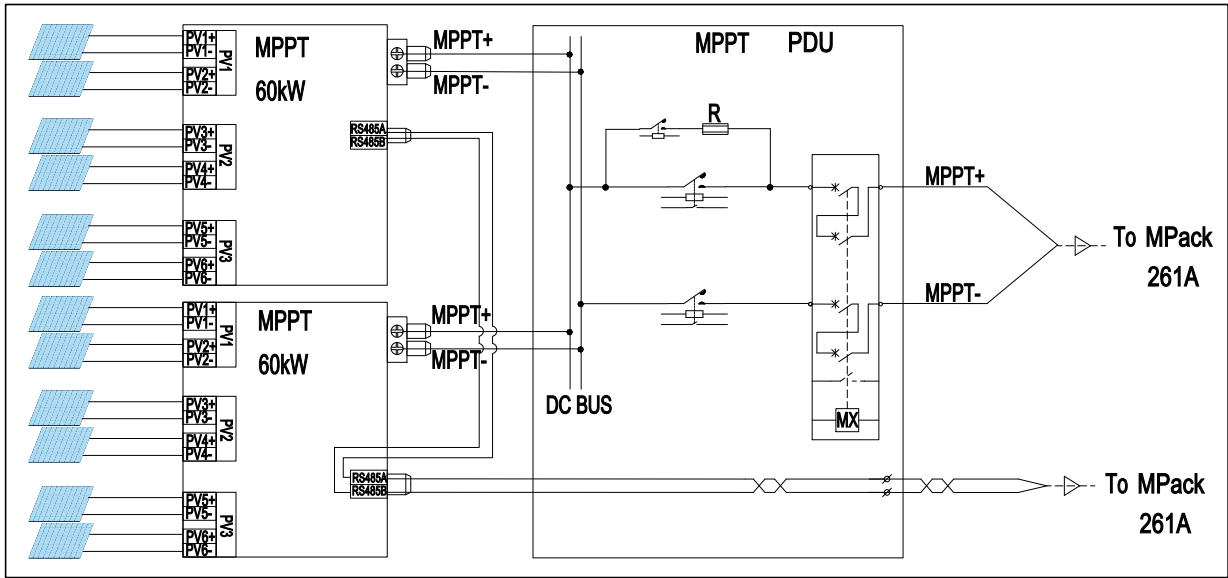

### 5.1.3. STS Box (Optional)

#### ① Single-Module Configuration

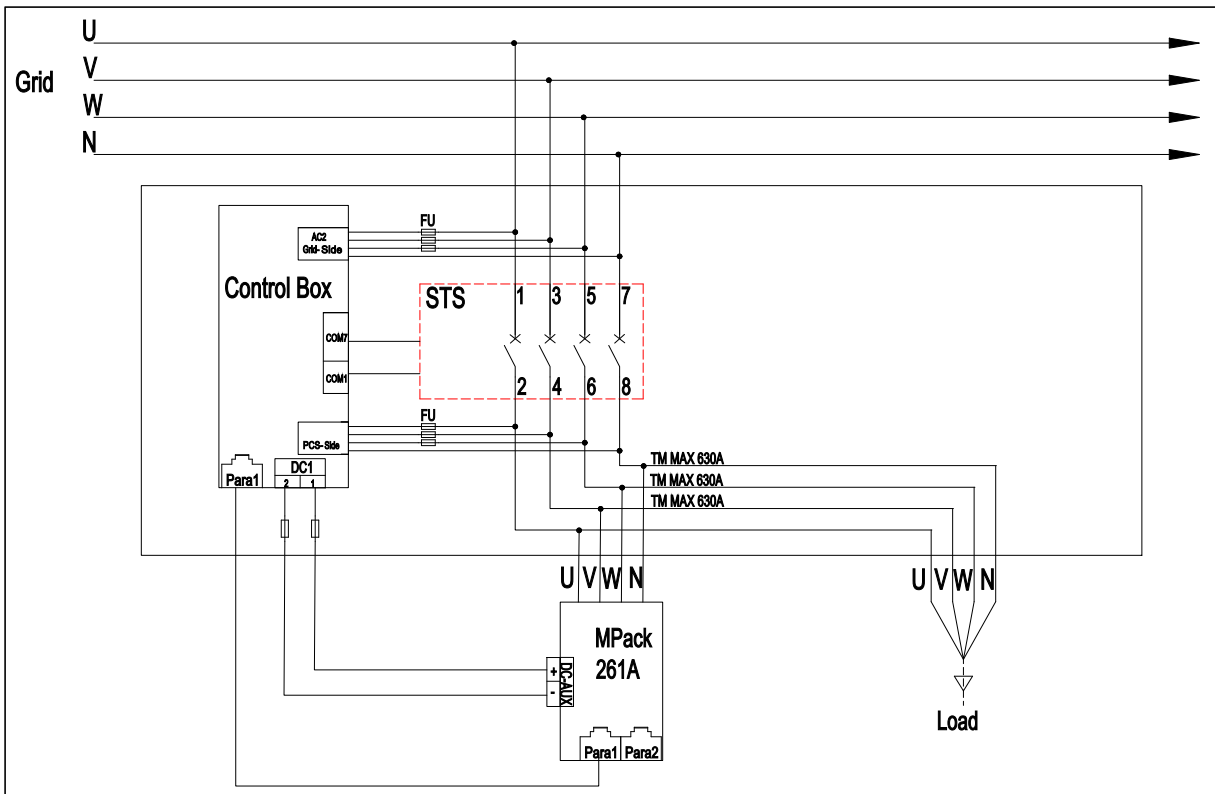

② Dual-Module Configuration

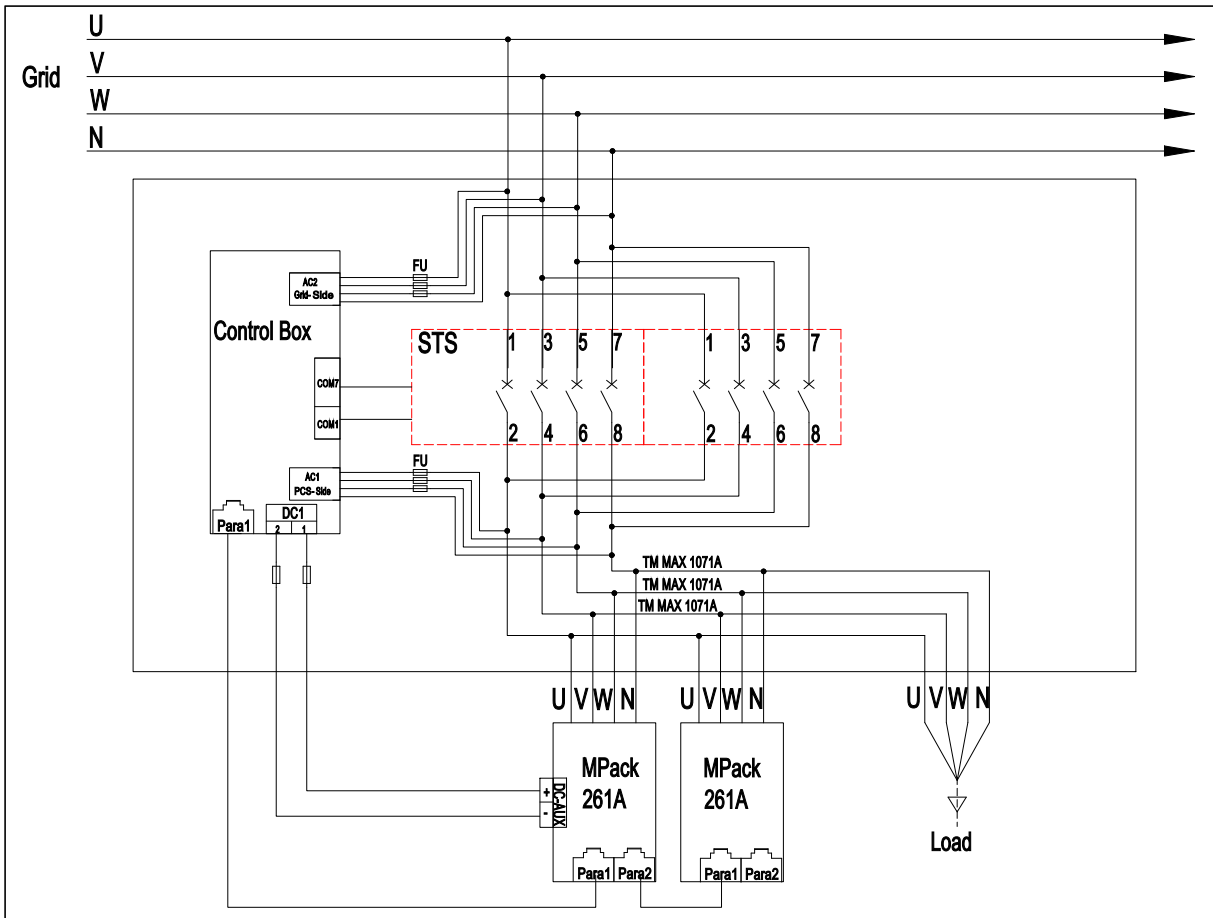

**Danger**

















- All electrical connections must be strictly made in accordance with the wiring diagram/schematic.
- All electrical connections must be performed only when the equipment is completely de-energized.

## 5.2. Pre-Wiring Preparation

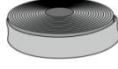

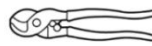
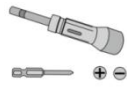

### 5.2.1. Tool Preparation

Prior to installation, prepare all necessary installation tools (e.g., insulated socket wrenches, screwdrivers) and personal protective equipment (PPE). All tools used must be of an insulated type.

#### (1) Installation tools

Type	Tools and Instruments		
Installation Tools	 Crimping Pliers	 Socket TorqueWrench	 Impact Drill
	 Torque Wrench	 Diagonal Cutting Pliers	 Wire Stripping Pliers
	 Hot Air Gun	 Vacuum Cleaner	 Marker Pen
	 Level	 Heat Shrink Tubing	 Cable Ties
	 Multimeter	 Rubber Mallet	 Steel Tape Measure
	 Utility Knife	 Lineman's Pliers	 Torque Screwdriver

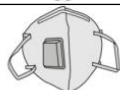
#### (2) Personal Protective Equipment (PPE)

Type	Tools and Instruments		
PPE	 Goggles	 Safety Shoes	 Safety Gloves
	 Dust Mask	 Insulating Gloves	

### 5.2.2. Cable Preparation

Equipment	Cable Type		Section	Remark
Battery Cabinet	Protective Earth Cable	Protective Grounding (PE)	Section 5.3.1	User-supplied
		Functional Grounding (FG)	Section 5.3.2	User-supplied
	Auxiliary Power Supply Cable		Section 5.4	User-supplied
	AC Cable		Section 5.5	User-supplied
	DC Cable		Section 5.6	User-supplied
	Communication and Control Cable (Reserved)		Section 5.7	User-supplied

**Note**

- The cable specifications and colors depicted in this manual are for guidance only. Users shall select cables that comply with local codes and regulations. The recommended conductor cross-sectional areas are provided in the specifications below.
- Selected cables must:
  - ① Be properly sized to carry the maximum expected current with adequate ampacity
  - ② Include sufficient length allowance for routing and termination.
  - ③ Be flame-retardant (preferred).

### 5.3. Protective Earth Cable Connection

#### 5.3.1. Protective Grounding (PE)

The cabinet enclosure has two grounding terminals; connect either one to the grounding electrodes (e.g., ground rod or grounding grid).

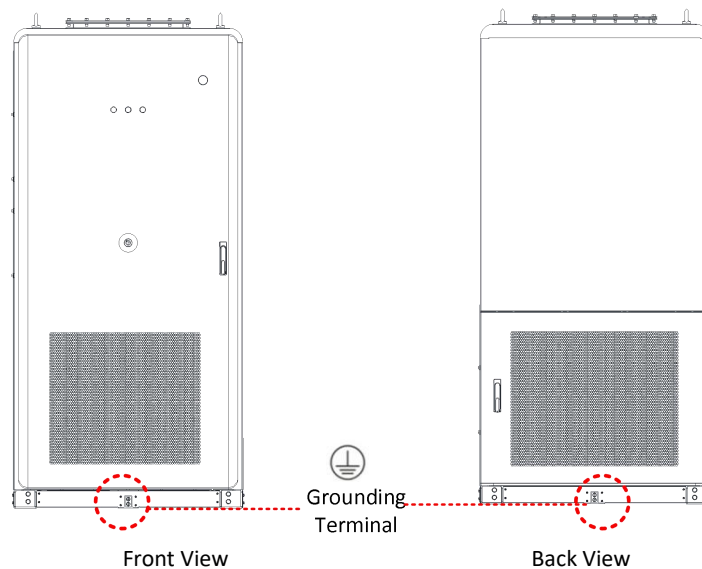

No.	Name	Specification
1	Recommended Cable	35mm <sup>2</sup> (2AWG)
2	Connection terminal	SC35-10 (Torque: 22N-m)

### 5.3.2. Functional Grounding (FG)

Connect the Internal ground busbar to the grounding electrode (e.g., ground rod or grounding grid).

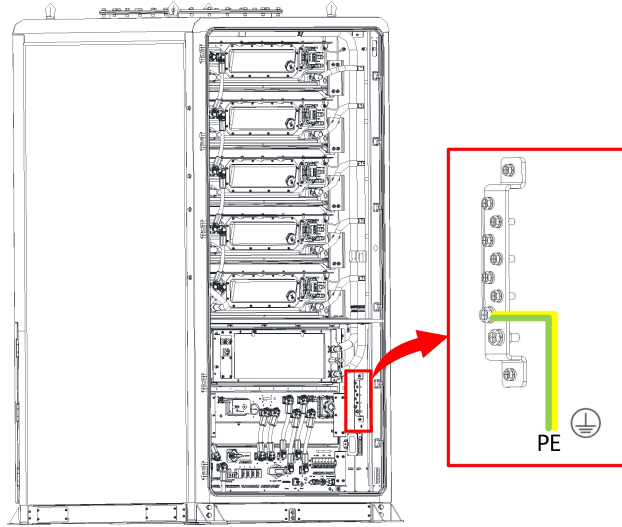

✓ The internal busbar (Front View)

No.	Name	Specification
1	Recommended Cable	35mm <sup>2</sup> (2AWG)
2	Connection terminal	SC35-8 (Torque: 14N·m)

### 5.4. Auxiliary Power Supply Cable Connection

Connect the **external auxiliary power supply (User-supplied, AC 190-250V, Power≥5kW, 50/60Hz)** to the terminal block of MPack 261A.

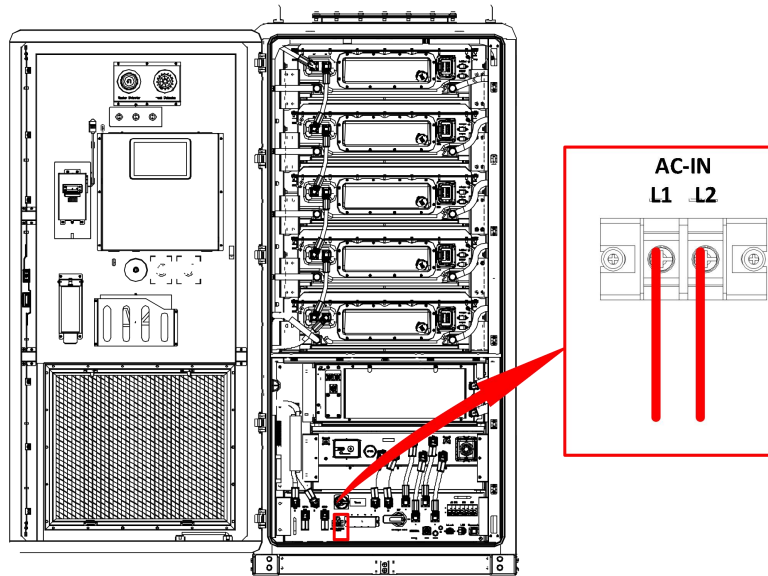

✓ Front View

No.	Name	Specification
1	<b>Requirement for Auxiliary Power Supply</b>	<b>AC 190-250V, Power≥5kW, 50/60Hz</b>
2	Recommended Cable (Per Phase)	L1/L2, 4mm <sup>2</sup> (12AWG), Rated Voltage ≥600VAC
3	Connection terminal	RNB 5.5-5 (Torque: 3N·m)

### 5.5. AC Cable Connection

Connect the AC cable(U/V/W/N) from the MPack 261A to the grid.

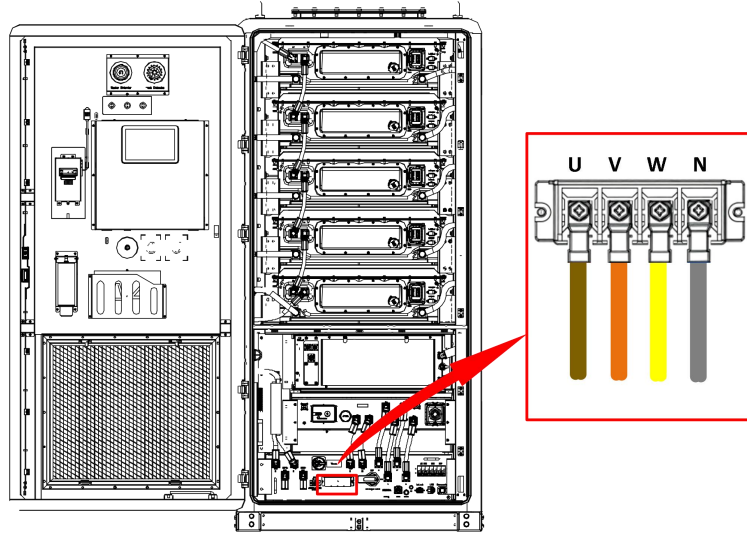

✓ Front View

No.	Name	Specification
1	Recommended Cable (Per Phase)	70mm <sup>2</sup> (2/0AWG)
2	Connection terminal	SC70-8 (Torque: 14N·m)

### 5.6. DC Cable Connection

This DC interface is designed for connection to the external MPPT Unit. If the MPPT Unit is not equipped, this interface remain unused and must not be connected directly to another battery cabinet.

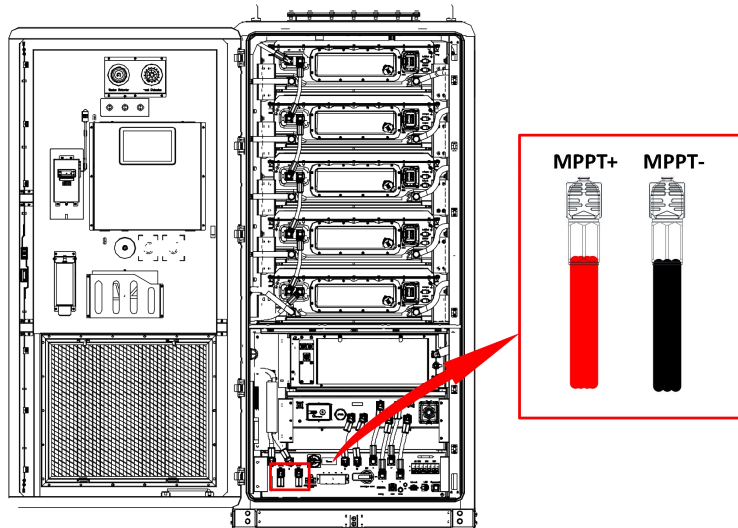

✓ Front View

No.	Name	Specification
1	Recommended Cable (Per Phase)	70mm <sup>2</sup> (2/0AWG)
2	Connection terminal	FSE80110P-95A4K 320A

### 5.7. Communication and Control Cable Connection (Reserved)

The reserved communication and control interfaces of the MPack 261A are shown below.

Interface	Quantity	Description
Ethernet (LAN)	3 ports	1) ETH0: For connection to the host computer/ external network/ external EMS. 2) Para1&Para2: For the communication cable between two parallel MPack 261 units. Use a Cat.5e cable with an RJ45 connector.
RS485	1 branch circuit	XT1 Terminal Block (XT1:18, XT1:20): For the grid/load-side meter communication.
CAN	2 branch circuits	XT1 Terminal Block (XT1:9~12): Reserved for Buyer communication access.
Control Interface	4 branch circuits	1) I/O Expansion Module (Y6, Y7, Y8): Dry Contact 2) I/O Expansion Module (INPUT: X4~8): DI (active high)

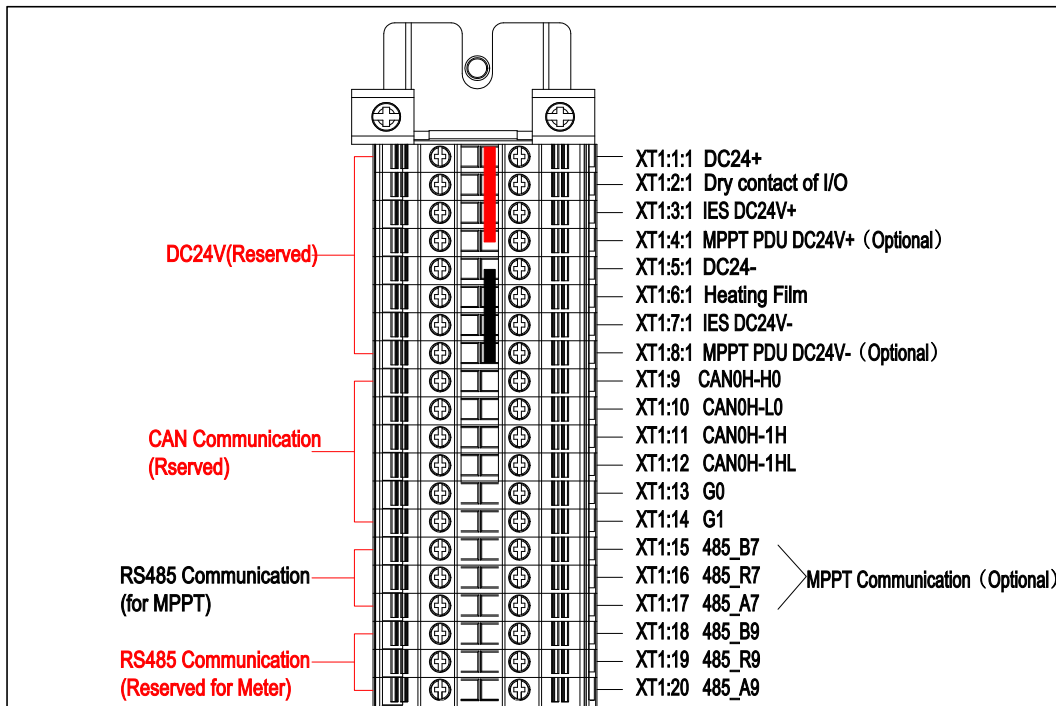
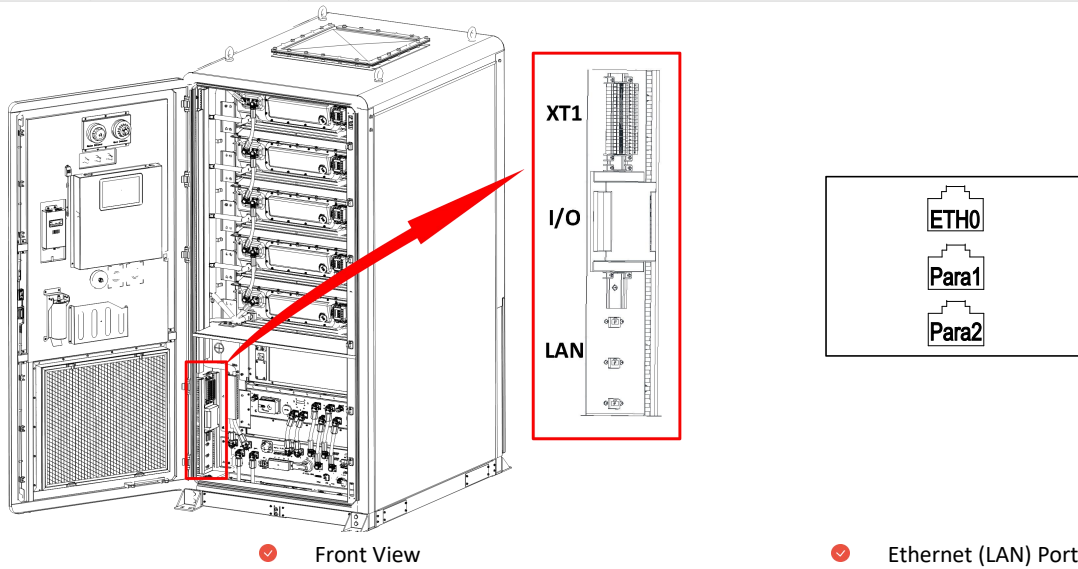

✔ Pin Definition (XT1 Terminal Block)

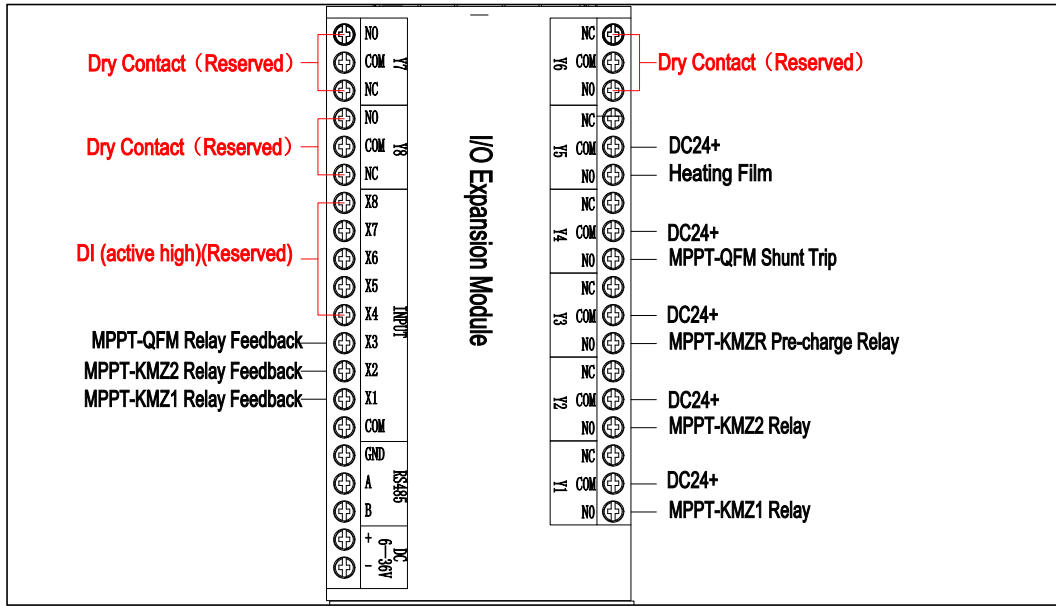

Pin Definition (I/O Expansion Module)

No.	Name	Ethernet (LAN)	RS485	CAN	Control Interface
1	Recommended Cable	Cat.5e	0.5mm <sup>2</sup> (22AWG)	0.5mm <sup>2</sup> (22AWG)	0.5mm <sup>2</sup> (20AWG)
2	Connection terminal	RJ45	E0510 Pre-insulated Pin Terminal		

### 5.8. Battery Maintenance Switch Disconnect Device (MSD)

Installation of MSD should be conducted after the fixation of racks and harness.

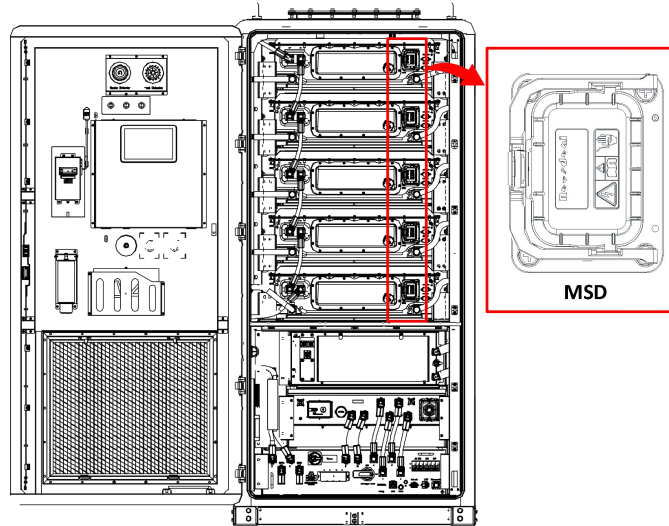

Front View

Install the MSD cover onto the battery module by:

1. Aligning the maintenance switch cover handle vertically with the base guide slot and pushing inward.
2. Rotating the handle after full insertion.
3. Audibly confirming the 'click' engagement.
4. Securing the secondary lock (reverse for removal).

## 6. Test Operation of Equipment

### 6.1. Check Before Charging

No.	Check items
1	The cabinet is securely installed in a well-ventilated, accessible location, ensuring easy operation, maintenance, and heat dissipation, within a clean and tidy environment.
2	All cables are correctly and firmly connected. Cable binding meets the wiring requirements, reasonable distribution and no damage.

### 6.2. Power On

Note
Before initially energizing the AC side, qualified personnel shall close the upstream grid switch to apply power to the energy storage cabinet's connection point. Upon energization, the voltage and frequency shall be verified to be within specified limits at that point, and the phase sequence shall be confirmed as correct using a phase sequence meter.

#### Power on Steps:

1. Verify the emergency stop button, and ensure it's release.
2. Verify the AC circuit breaker is in the OFF position.
3. Verify that the lightning protection (QF-SPD) circuit breaker in the rear cabinet is closed.
4. Under manual mode, turn the fused switch to the ON position by hand. Then, change the switch to the Auto mode.
5. Turn the AC auxiliary supply power circuit breakers to the ON position, following this sequence:  
①First the AC BUS circuit breaker ②Then other circuit breakers (LCU、PDU).
6. Turn the DC isolation switch to the ON position.
7. Press the Power button to turn it on.
8. Turn the DC isolation switch to the OFF position.
9. Turn the AC circuit breaker to the ON position.

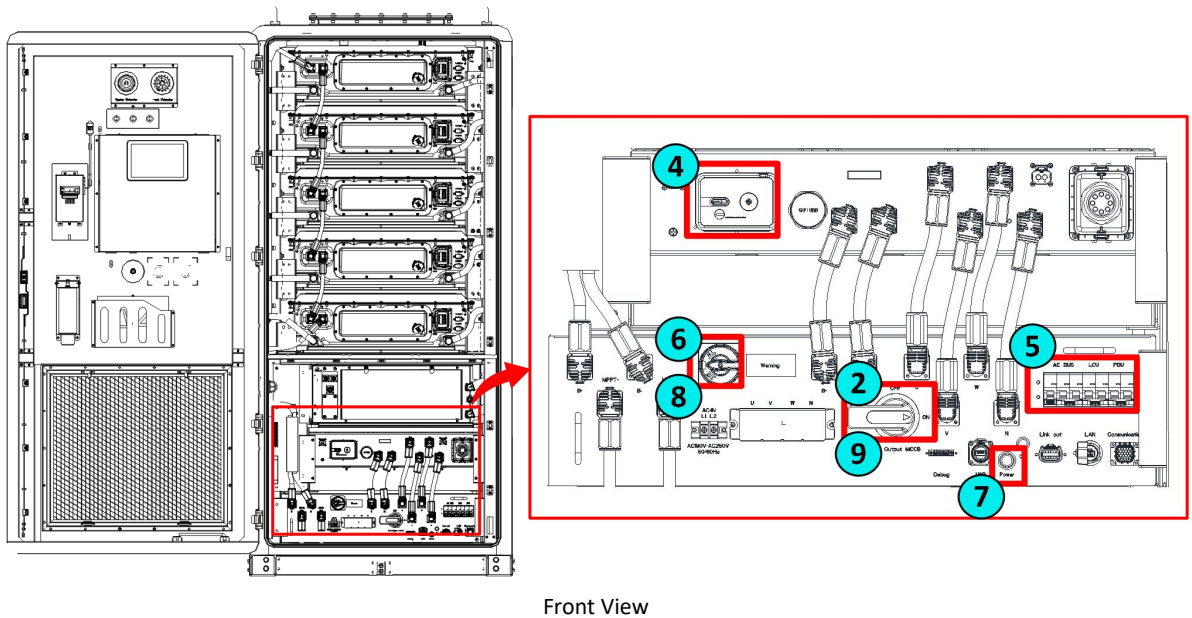
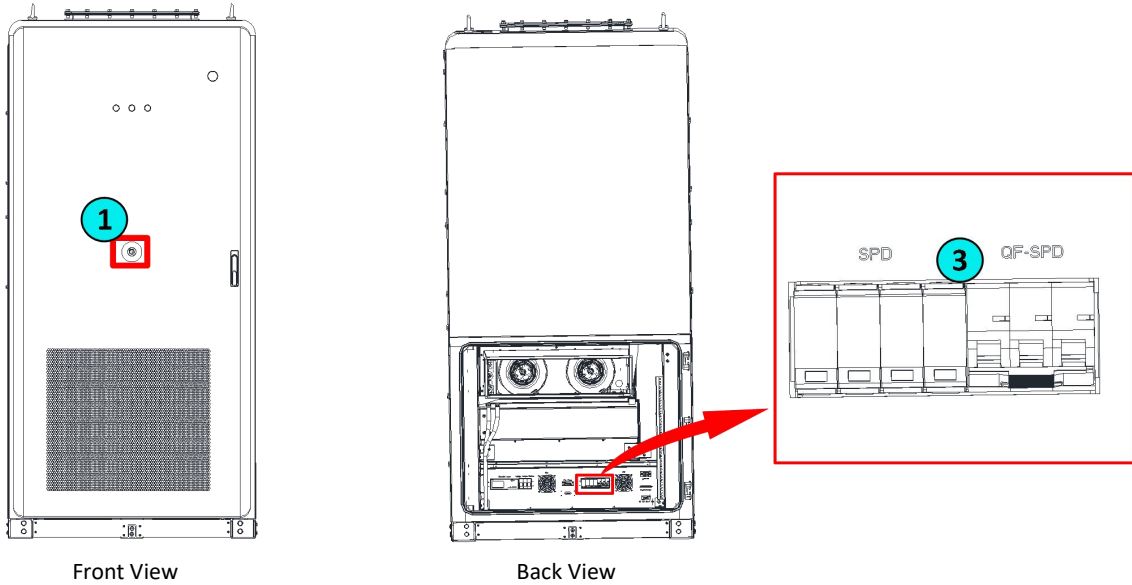

Operating Instructions of the fused switch:

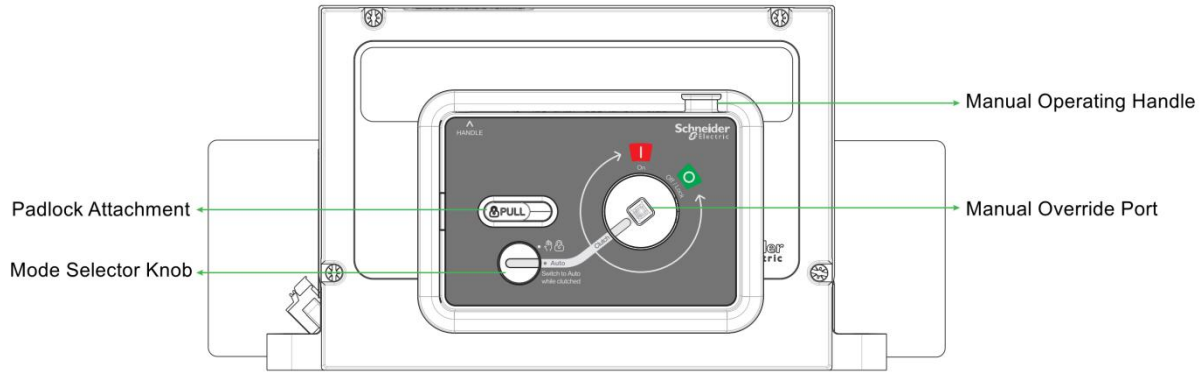

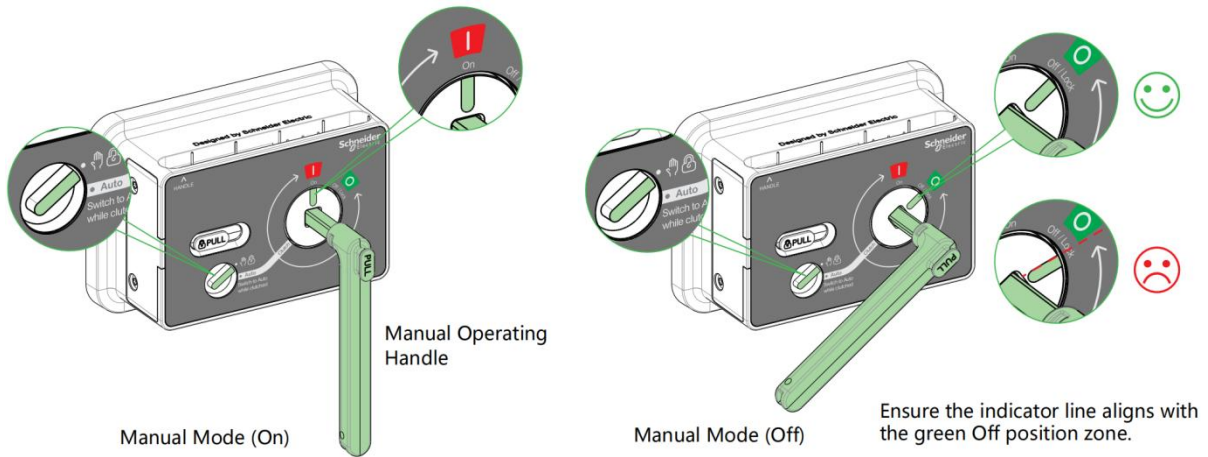

### 6.3. Power Down

Power down Steps:

1. Shut down the system via the display interface (do not power off while high-power loads are active).
2. Turn the AC circuit breaker to the OFF position.
3. Press the Power button to turn it off.
4. Turn the AC auxiliary supply power circuit breakers to the OFF position, following this sequence: ① First open the AC BUS circuit breaker ② Then open other circuit breakers (LCU、 PDU).

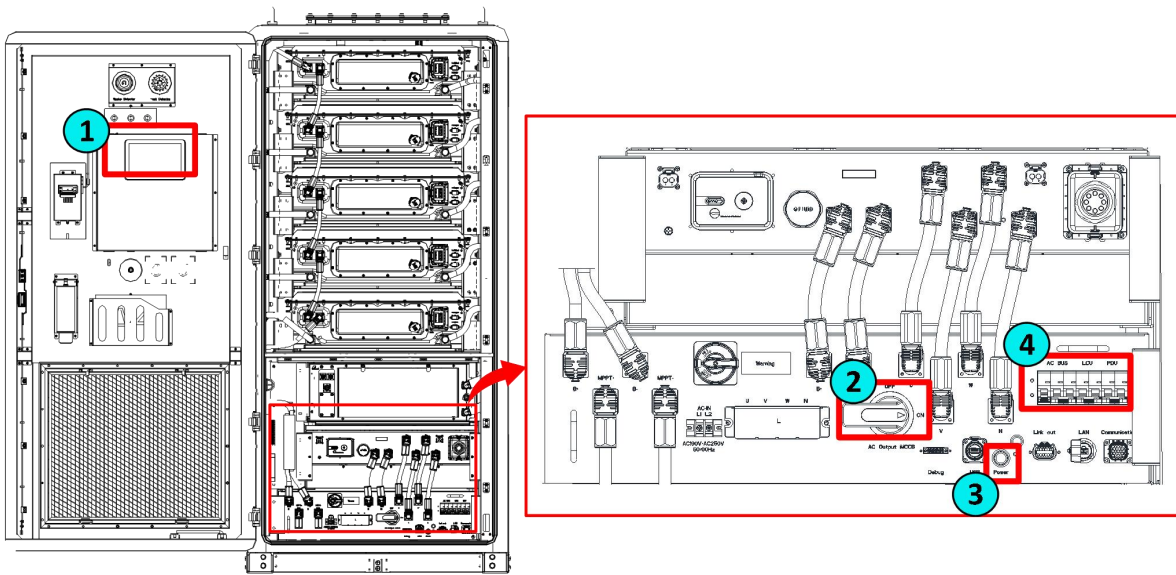

Front View

### 6.4. Equipment Door-close

Note	
➤	After the ESS is powered on, if there is no abnormal situation, please close the equipment door.
➤	Close the equipment door and keep the key properly.

## 6.5. Emergency Stop

Emergency Stop Button in battery cabinets serves as a critical safety device designed to immediately cut off power or halt system operation during emergencies, effectively preventing personnel injuries, equipment damage, and other dangerous scenarios.

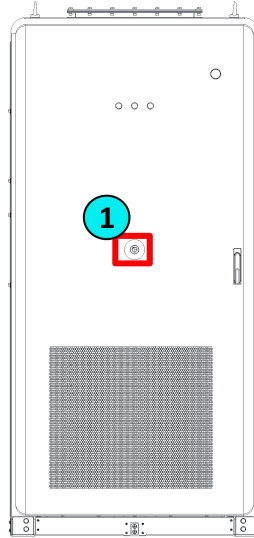

## 7. Revision Table

The manual revision history is tracked in the following table:

Revision Number	Date (MM/DD/YYYY)	Description
1.0	Dec 20, 2025	Initial version

## Technical Support

Email: [support@renonpower.com](mailto:support@renonpower.com)

---

### Renon Power USA LLC

580 McIntyre Rd. McKinney, TX 75071

---

### Renon Power Technology B.V.

Rietbaan 10, 2908 LP Capelle aan den IJssel

---

### Renon Power 株式会社

東京都中央区日本橋箱崎町 20-5 VORT 箱崎 5F



LinkedIn



Website